

# HyCare™

*The progressing cavity pump that protects the fruits of your labour*



QUALITY – SAFETY – EFFICIENCY

PCM Moineau™



Keep it  
moving



# Quality

*HyCare™ protects the quality and texture of your products*



*Quality, safety and efficiency are the three ingredients PCM has used to create the new HyCare™ progressing cavity pump*

## *We share your commitment to excellence*

Featuring a patented body design developed using advanced computational fluid dynamics, PCM HyCare™ is the world's gentlest, most hygienic progressing cavity pump for food-grade applications. It's the first food-grade PCP to treat your ingredients, food safety requirements and budget with equal care.



## Moineau™ technology at the heart of HyCare™



The HyCare™ pumps are used in the last stages of the process, when the product is almost finalized. That is the moment when it is crucial to protect the texture and ingredients.

**Moineau™ technology provides the best protection for the valuable pieces and texture of your product.**

The internal slip flow, which causes shear in the product, is controlled by tightening the elastomer stator in the rotor. This characteristic provides a decisive advantage over metal/metal technologies such as lobe pumps in terms of protecting the texture and visual or taste qualities of your products.

*Comparison of HyCare™ performances versus bi-wing and lobe pump technologies. [1]*

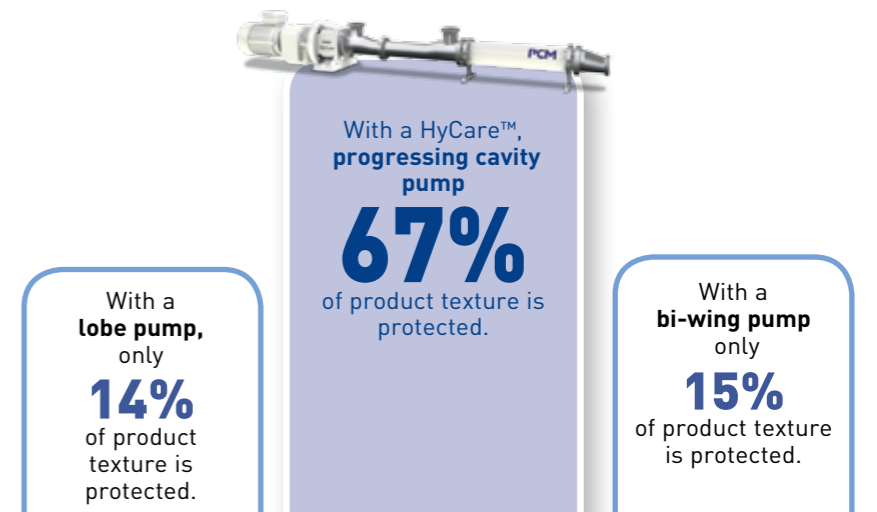

[1] Results of tests performed at the PCM Flow Technology Centre on a model fluid with characteristics similar to yoghurt at 4 bars and 6 m<sup>3</sup>/H. The performance characteristics of a HyCare™ two-stage pump were compared to those of lobe and bi-wing pumps of equivalent sizes and capacities.



### Operation

A Moineau pump consists of a helical rotor turning inside a helical stator. The stainless steel rotor is machined to a high degree of precision, and the stator is molded in a resilient elastomer. The geometry and the dimensions of these parts are such that when the rotor is inserted into the stator, a double chain of watertight cavities (honeycombed-shaped) is created. When the rotor turns inside the stator, the honeycomb progresses spirally along the axis of the pump without changing either shape or volume. This action transfers the product from the pump intake to the pump discharge without degrading the product.

### Features

- Handles both fragile and viscous products
- High suction and self-priming capabilities
- Constant non-pulsating flow
- Easy to maintain
- Reversible
- Flow rate proportional to running speed
- Flow rate proportional to the speed of rotation.

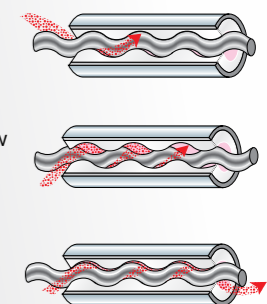



# Safety

A partner in your commitment to consumers

## HyCare™, the cleanest progressing cavity pump on the market

PCM used computational fluid dynamics (CFD) to develop the Duraflex flexible shaft, guaranteeing food safety for consumers.

With 3-A and EHEDG certification, the HyCare™ pump guarantees optimum hygiene for your process.

### A unique design approved by the most stringent food standards

**3-A** An independent auditor has declared the design of the HyCare™ pump and its manufacturing process compliant with the American Standard 3-A. This standard regulates the American dairy industry and, more generally, is the guarantee of an advanced hygienic design for the food industry.



**EHEDG** The HyCare™ pump is one of the few progressing cavity pumps to have passed the European Hygienic Engineering and Design Group's CIP cleaning tests. Its innovative hygienic design is recognized by EHEDG EL Type certification, which guarantees optimum effectiveness of the CIP system.



### Materials that comply with international laws

The materials in the HyCare™ pump (stators, gaskets, mechanical seals) comply with the following standards:

- European Directive EC 1935/2004
- American FDA (Food and Drug Administration) regulations
- The American USP (United States Pharmacopoeia) Standard.



## CFD to promote hygiene

PCM has optimized the internal design of the HyCare™ pump and improved the cleaning in place effect by 30% thanks to its expertise in Computational Fluid Dynamics (CFD). This result was obtained by increasing the speed of the cleaning fluid and by studying the currents in the most difficult areas to clean.

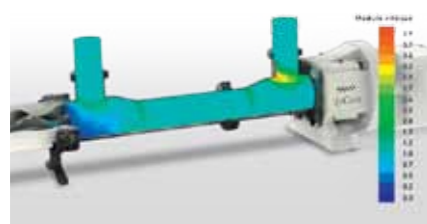

Cleaning-in-place (CIP) fluid speeds modelling in the body of the HyCare™ pump using CFD.



## Duraflex, the flexible shaft designed for CIP

The Duraflex flexible shaft has a one-piece design without any possible retention area, unlike the classic open joints. The total absence of wear parts prevents any risk of metal particles being released into the product.



# Efficiency

HyCare™ optimizes your production

## HyCare™ optimizes your production

### HyCare™, is the shortest hygienic progressing cavity pump on the market.

Equipped with the new Duraflex flexible shaft, HyCare™ is 20% shorter. This significantly decreases integration and transport costs.

### Greater efficiency

The internal volume of the HyCare™ pump is 50% smaller thanks to the innovative design of the body and the Duraflex flexible shaft. This reduces product loss at the end of production to an absolute minimum.

The savings achieved mean that you will recover your investment on the HyCare™ pump in just a few months.

### The energy efficiency of Moineau technology

Moineau technology has amongst the best hydraulic efficiency ratings of any positive displacement pump thanks to a slip flow that is controlled by the tightening between rotor and stator. The constant flow rate allows the pump to remain highly efficient despite any variations in viscosity or pressure. This results in motors that consume less energy and correspondingly lower operating costs.

## Reliable in every situation

- Duraflex flexible shaft made of hard-wearing titanium (compared to open joints).
- Patented stator anti-rotation system, ensuring safe operation in the event of high pressure or temperature.

## Simplified maintenance

- No maintenance on the flexible shaft (no joint).
- Mechanical seal in a cartridge (no adjustment).
- Quick and simple disassembly thanks to the two-part body and the shafting assembly system.



# Technical features of the HyCare™ pump

Design 13HY24 to 90HY12

## Performance of the HyCare™ pump

Pressure up to 24 bars  
Flow rate up to 40 m³/h  
Particle size up to 32 mm

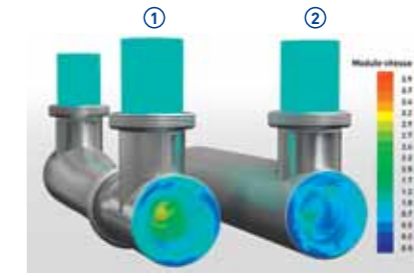

Effect of the inlet tangential design on the speed of the CIP fluid at the rear of the pump.  
① HyCare™ design with tangential inlet connection  
② Classic design

**3 Optimized body design,** with CFD technology to improve the effect of the cleaning and reduce production losses. It is made of 316L stainless steel, in a two-part design for easy maintenance.  
(Only available for 13HY24 to 90HY12 design)

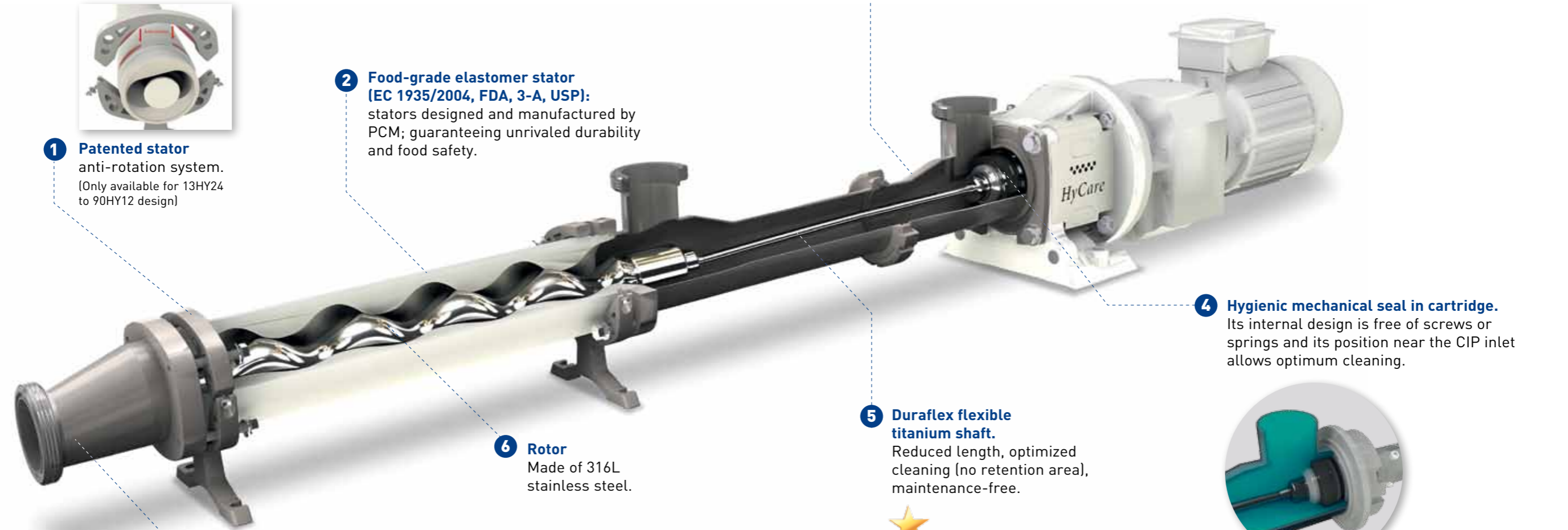

**1 Patented stator** anti-rotation system.  
(Only available for 13HY24 to 90HY12 design)

**2 Food-grade elastomer stator** (EC 1935/2004, FDA, 3-A, USP): stators designed and manufactured by PCM; guaranteeing unrivaled durability and food safety.

**6 Rotor**  
Made of 316L stainless steel.

**4 Hygienic mechanical seal in cartridge.** Its internal design is free of screws or springs and its position near the CIP inlet allows optimum cleaning.

**5 Duraflex flexible titanium shaft.** Reduced length, optimized cleaning (no retention area), maintenance-free.



**7 Eccentric pipe.** Prevents any product retention.



Pipe with built-in CIP bypass (optional) Upward pipe (option)



HyCare™ Design 05HY12 to 13HY12





## ↘ Industries and applications

In every area of the food industry



**Dairy products**  
Stirred yoghurt, set yoghurt, curd cheese, butter, creams, desserts, ferments, rennet, milk, oil, ice cream, eggs, fruit preparations, vitamins, flavours, etc.



**Meat, fish, animal feed, egg products**  
Meat emulsions, surfine, mincedmeat, fodder, chicken, fish with or without pieces, surimi, oils, flavours, colorants, fats, proteins, enzymes, etc.



**Bread, cakes, pastries**  
Butter, jam, water, oil, eggs, yeast, dough, biscuit mix, gluten, fillings, sauces, chocolate, biscuit creams, sweet syrup, etc.



**Drinks**  
Juices, wine dregs and pressings, fruit concentrates, beer, etc.



**Fruits, vegetables**  
Fruit or vegetable purée, jam and jelly, fruit paste, compote, etc.



**Ready-made meals, sauces**  
Mayonnaise, mustard, ketchup, tomato sauce, oils, eggs, fish paste, baby food, etc.



**Cosmetics and pharmaceutical products**  
Creams, shampoo, liquid soap, body milk, resin, oil, plant extracts, etc.