

KRAL Screw Pumps.
Overview.

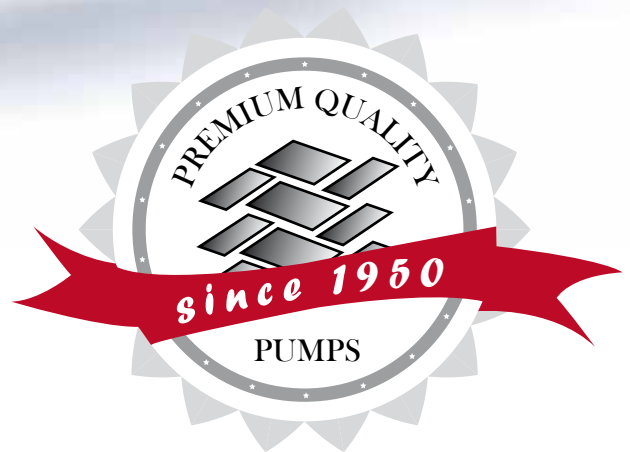

■■■■■■■ Pumps

Welcome to KRAL.

KRAL AG is a family business. Our customers include many enterprises active worldwide.

KRAL stands for quality, innovation and quick response – anytime and anywhere around the world.

KRAL AG is headquartered in Austria. The company is the innovation leader in the specialized industrial sector including pumps and flowmeters. KRAL solutions bring our customers greater success in their competitive environments, providing the highest level of value. In close cooperation with customers, we not only focus on pumps and related technology, but also entire systems along with strategic planning. This results in the realization of customer specific solutions.

Our customers like working with KRAL. Friendliness and a positive cooperative environment have been shown in our high marks in customer satisfaction surveys. These scores represent essential success factors. They are a result of our professionalism and dedication in all areas of the business.

KRAL partners with global players. Such firms need solid, dependable partners. The AG forms the foundation of a solid and powerful market presence. The family aspect of KRAL means that you can rely on an engaged and cooperative partner in the years to come.

The human factor is at the core of our decision. Success is the result of the positive cooperative efforts of KRAL customers, distributors and personnel.



At Home Worldwide.

For our clients on every continent.



You can find your personal KRAL representative on our website:
www.kral.at/en/contact

Screw Pumps From KRAL.

An overview of the technological advantages.

■ **Efficiency.**

In comparison to other types of pumps, KRAL screw pumps offer a high delivery rate but don't take up a lot of space. KRAL pumps are low in pulsation and run quiet.

■ **Wear reducing surface treatment.**

A special heat treatment of the pump housing minimizes friction and wear.

■ **Optimal cooling and lubrication.**

The application specific design of the balancing cylinder ensures proper cooling and lubrication of the sealing surfaces of the mechanical seals.

■ **Self-purging.**

Venting between the positive pressure side and the negative pressure side directly depends on the mechanical seal. In this way, it's ensured that the air buffer through the medium in the vent line can be eliminated, even for vertical installation.

■ **Optimized flange construction.**

Flanges are constructed according to ISO 3019. This means that KRAL pumps can be connected to common pump mounts. The type of construction used minimizes the size for an optional magnetic coupling.

■ **No accumulation of residue.**

Leakage from the mechanical seals is directly diverted from the stationary seal ring via a vent hold. There is no unnoticed accumulation of residue that might damage the bearings.

■ **Top quality SiC development.**

The highly developed SiC quality of our mechanical seals contain graphite as a dry lubricant. This reduces damaging friction during dry operation.

■ **Durable o-rings.**

High quality o-rings are chemically stable and can withstand high temperatures of up to 180 °C.

■ **Standard seals.**

Depending on the requirements of the application, various types of mechanical seals are available that conform to DIN 24960.

■ **Optional seals.**

Standard seals are available with various qualities. Options include magnetic couplings, radial seal rings and mechanical seals with fluid (quench type).

■ **High quality bearings.**



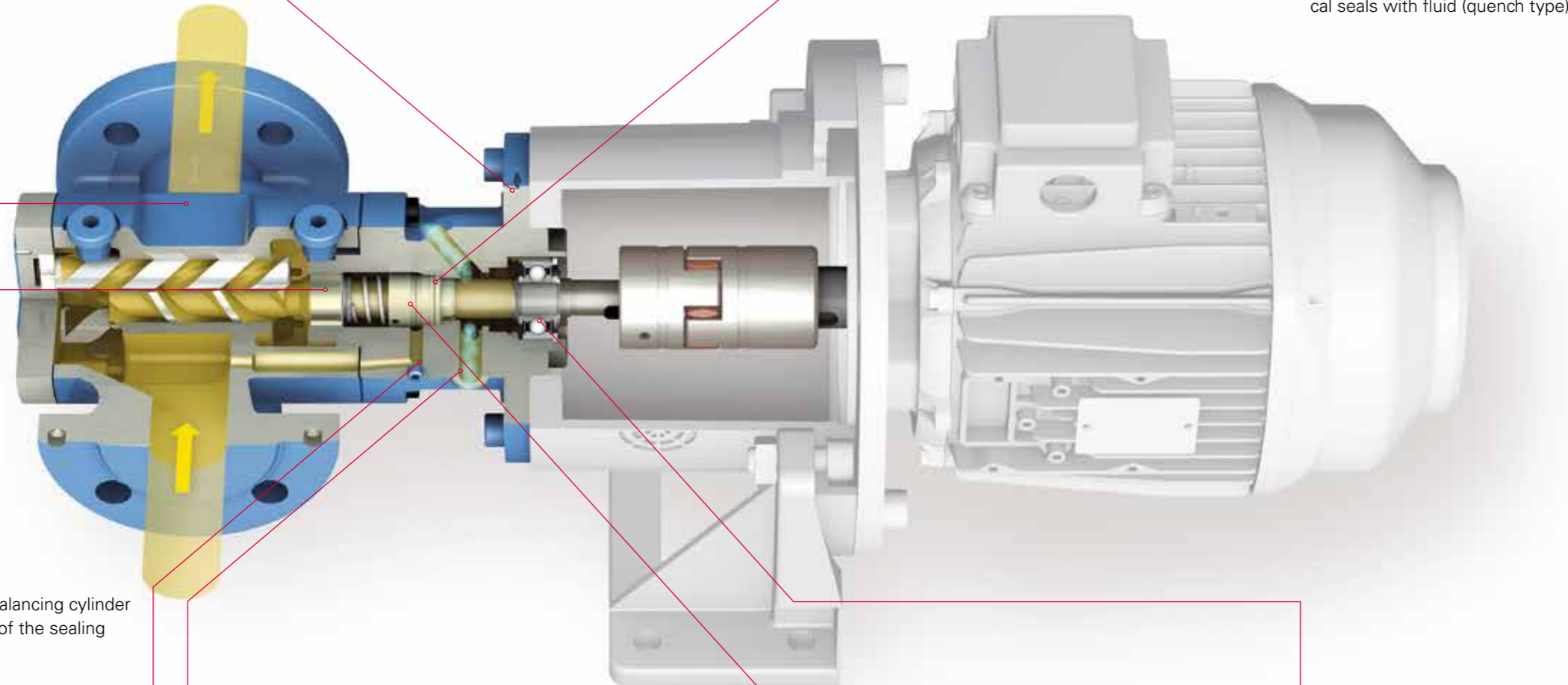



KRAL pumps are equipped with lifetime lubricated and sealed bearings. This increases the lifespan and reduces maintenance costs.



The Right Pump Series for Your Needs.

Here you'll find an overview of the most important information.



 Delivery Rate.	 Pressure.	 Temperature.	 Series.	 Position in the KRAL product line.	 Page.
5 to 2,900 l/min 0.3 to 174 m ³ /h	16 bar	-20 to 180 °C	K	This economical, most sold KRAL pump can be used at pressures up to 16 bar.	8-9
5 to 200 l/min 0.3 to 12 m ³ /h	63 bar	-20 to 180 °C	L	The mid-pressure pump from KRAL. Robust, low wear and easy to maintain.	10-11
5 to 3,550 l/min 0.3 to 213 m ³ /h	100 bar	-20 to 180 °C	C	The all-rounder – when needs exceed the standard K or L series pumps.	12-13
15 to 290 l/min 0.9 to 17.4 m ³ /h	120 bar	-20 to 180 °C	W	The pump for special applications, for example contaminated, abrasive or low viscosity media.	14-15
5 to 3,550 l/min 0.3 to 213 m ³ /h	100 bar	-20 to 300 °C	Magnetic coupling	KRAL magnetic couplings are maintenance free, hermetically sealed and can be used at temperatures up to 300 °C.	16-17
5 to 280 l/min 0.3 to 16.8 m ³ /h	40 bar	-20 to 180 °C	Compact Station EK, EL	This is a commercial/economical oil burner pump with additional functions.	18-19
5 to 280 l/min 0.3 to 16.8 m ³ /h	40 bar	-20 to 180 °C	Compact Station DKC, DLC, DS/L	Dual pumps are ideal when redundancy and greater safety are needed.	20-21
5 to 3,550 l/min 0.3 to 213 m ³ /h	100 bar	-20 to 180 °C	Single Station	Available in a standard design, or can be set up according to specific customer needs.	Information available on request.
5 to 3,550 l/min 0.3 to 213 m ³ /h	100 bar	-20 to 180 °C	Double Station	Available in a standard design, or can be set up according to specific customer needs.	Information available on request.

K Series.

The economical, most sold KRAL pump.



Operation, materials, components.

- Delivery rate: 5 to 2,900 l/min.
- Delivery rate KFT: 5 to 510 l/min.
- Max. differential pressure: 16 bar.
- Temperature range: -20°C to 180°C, magnetic coupling to 300°C.
- Housing: Nodular cast iron EN-GJS-400.
- Spindles: Steel, nitrided.
- Certifications: ABS, BV, CCS, DNV, GL, LRS, MRS, NK, RINA.
- ATEX: Ⓜ II 2 GD b/c group II, category 2.
- Heating: Electrical, fluid media and steam.

Universal use up to 16 bar.

K series pumps are universal screw pumps, making them the most sold KRAL pump. The K pumps have a feed pressure of 16 bar and housing made from nodular cast iron. They are approved for use onboard ships. In addition, they are equipped with sealed external bearings that are pre-lubricated for their lifetime so they are not stressed by the material being pumped and require no maintenance.

Models and installation variants.

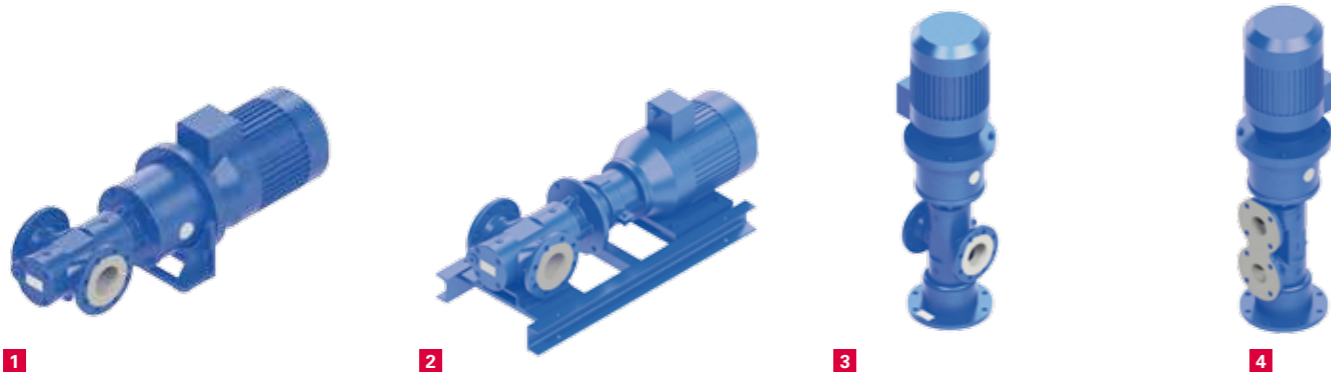

1 The **KF flange pump** is the universal pump for horizontal installation.

2 **KH foot pump** – mounted onto base frames.

3 The **KV pedestal pump** is the right choice if the installation area is narrow or if there is not enough available space for large pumps.

4 **KFT pumps** have overhead DIN PN16 flanges for horizontal or vertical installation.

Industrial uses.



Marine.

- Delivery and circulation of fuel and lubricants.
- Increasing pressure and circulation for booster modules.
- Increasing pressure and circulation in lubrication systems.
- Tank system support.
- Increasing pressure and circulation for separators.
- Burner pump for boilers.
- Supplying fuel to diesel engines.



Oil & Gas.

- Transfer of separated crude oil.
- Increasing pressure and circulation for lubrication systems.
- Tank system support.
- Compressor lubrication.
- Filling and draining of tanks and transfer facilities.
- Pumping of bitumen, crude oil, diesel and HFO.



Power Generation.

- Burner technology for ring lines and transfer pumping.
- Supplying lubrication oil for large diesel engines.
- Supplying fuel for diesel engines.
- Increasing pressure and circulation in booster modules.
- Increasing pressure and circulation in lubrication systems.
- Tank system support.
- Increasing pressure and circulation for separators.
- Compressed oil shaft seals for hydrogen cooled generators.



Mechanical Engineering.

- Lubrication pumping for gears, motors, turbines and hydraulic systems.
- Increasing pressure and circulation in lubrication systems.
- Bench testing.
- Burner and transfer pumping.
- Lubrication oil applications.



Chemical Engineering.

- Plastics processing, in particular polyurethane applications.
- Drainage pumping in tank systems for adhesives, wax, resins and PUR.
- Increasing pressure and circulation in lubrication systems.
- Apportioning of fluids.
- Tank system support.
- Drum discharge pump.
- Filling and draining of tanks.

L Series.

Our middle pressure pump.



Operation, materials, components.

- Delivery rate: 5 to 200 l/min.
- Max. pressure: 63 bar.
- Temperature range: -20°C to 180°C, magnetic coupling to 300°C.
- Housing: Nodular cast iron EN-GJS-400.
- Spindles: Steel, nitrided.
- Certifications: ABS, BV, CCS, DNV, GL, LRS, MRS, NK, RINA, KR.
- ATEX: Ⓜ II 2 GD b/c group II, category 2.
- Heating: Electrical, fluid media and steam.

Robust, low wear and easy to maintain.

KRAL L series pumps offer clear options and are easy to service. From the smallest to the largest size, L pumps offer integrated top and inline flanges. Reliable startup, minimal wear and ease of maintenance simplify the operation of this line of pumps.

Models and installation variants.



- 1** The **LFI flange pump** is the universal pump for horizontal installation.
- 2** **LFT pumps** have overhead DIN flanges for horizontal installation.

- 3** The **LVI pedestal pump** is the right choice if the installation area is narrow or if there is not enough available space for large pumps.
- 4** Space saving **LVT pedestal pumps** are for vertical installation.

Industrial uses.



Marine.

- Burner pump for boiler systems.
- Delivery and circulation of fuel and lubricant.
- Increasing pressure and circulation in lubrication systems.
- Rudder adjustment.
- Propeller blade adjustment.



Oil & Gas.

- Increasing pressure and circulation in lubrication systems.
- Compressor lubrication.



Power Generation.

- Burner technology for ring line and transfer pumping.
- Supplying lubrication oil for large diesel engines.
- Increasing pressure and circulation in lubrication systems.
- Compressed oil shaft seals for hydrogen cooled generators.



Mechanical Engineering.

- Lubrication pumping for gears, motors, turbines and hydraulic systems.
- Increasing pressure and circulation in lubrication systems.
- Increasing pressure of refrigerants.
- Bench testing.
- Burner pump for industrial applications.
- Lubrication and hydraulic pump for plant facilities.



Chemical Engineering.

- Plastics processing, in particular polyurethane applications.
- Drainage pumping in tank systems for adhesives, wax, resins and fuel, PUR or coloring agents.
- Increasing pressure and circulation in lubrication systems.
- Apportioning of fluids.
- Process engineering.

C Series.

For pressures of up to 100 bar.



Operation, materials, components.

- Delivery rate CK: 1,750 l/min.
- Delivery rate CL: 3,550 l/min.
- Delivery rate CG: 3,550 l/min.
- Temperature range: -20°C to 180°C, magnetic coupling to 300°C.
- Pressure range: 70 bar; 100 bar.
- Housing: Nodular cast iron, steel and aluminium.
- Spindles: Steel, nitrided.
- Certifications: ABS, BV, CCS, DNV, GL, LRS, MRS, NK, RINA, KR.
- ATEX: Ⓜ II 2 GD b/c group II, category 2.
- Heating: Electrical, fluid media and steam.
- Manufactured to conform with API.

The all-rounder – when needs exceed the standard K or L series pumps.

The main components of the C series pumps are the same – the CK, CL and CG pumps differ in the details, delivering the right pump to match more demanding applications. These pumps are primarily used in industry. The CK line is used in hydraulics as a tank pump. The CL line is put to use in the plastics industry as a high pressure feeder pump for polyurethane components like polyols and isocyanates. CG pumps are utilized in all the same areas of industry as the K and L line when higher pressures and delivery rates are required.

Models and installation variants.

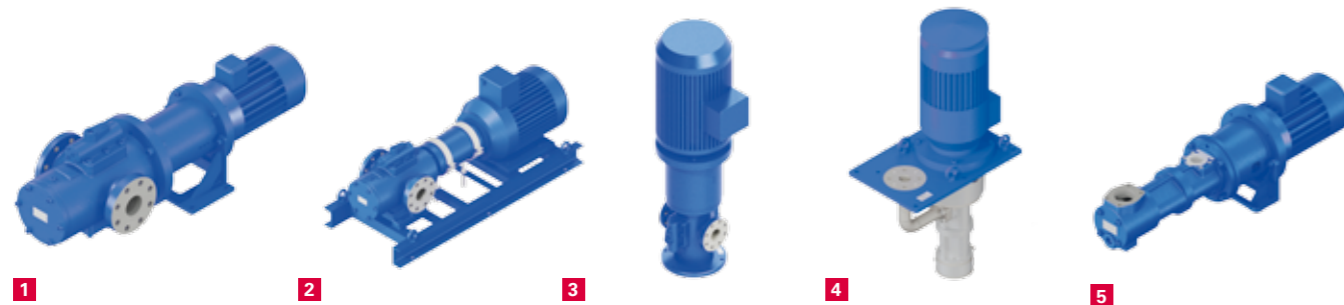

1 The **flange pump CGF** is the universal pump for horizontal installation.

2 **Pump CGH** – mounted onto base frames.

3 Space saving **CG pedestal pumps** are for vertical installation.

4 **CK/CL pumps** are suitable for in-tank installation.

5 The **CK/CL flange pump line** – universal horizontal installation pumps.

Industrial uses.



Oil & Gas.

- Transfer of separated crude oil.
- Increasing pressure and circulation in lubrication systems.
- Tank system support.
- Compressor lubrication.



Mechanical Engineering.

- Lubrication pumping for gears, motors, turbines and hydraulic systems.
- Increasing pressure and circulation in lubrication systems.
- Bench testing.
- Burner and transfer pump.
- Lubrication oil applications.
- Industrial burners.



Power Generation.

- Burner technology for ring line and transfer pumping.
- Supplying lubrication oil for large diesel engines.
- Increasing pressure and circulation in lubrication systems.
- Tank system support.
- Increasing pressure in hydraulic turbine controllers.
- Compressed oil shaft seals for hydrogen cooled generators.
- Raising turbine bearings.
- Industrial burners.



Marine.

- Providing service for hydraulic drives.
- Increasing pressure in lubrication systems.
- Tank system support.
- Burner pump, boiler pump.



Chemical Engineering.

- Plastics processing, in particular polyurethane applications.
- Drainage pumping in tank systems for adhesives, wax, resins and fuel, PUR or coloring agents.
- Increasing pressure and circulation in lubrication systems.
- Tank system support.
- Drum discharge pump.
- Filling and draining of tanks.

W Series.

The KRAL pump for special requirements.



Operation, materials, components.

- Delivery rate: 15 to 290 l/min.
- Max. differential pressure: 120 bar.
- Viscosity: > 1 mm²/sec.
- Max. temperature: to 180°C, magnetic coupling to 300°C.
- Installation: Wet or dry.
- Spindle housing: Nodular cast iron EN-GJS-400, polymer coated or other material options.
- Spindles: Steel, nitrided.

The pump for special requirements.

KRALs W series pump is mainly used wherever a dirty or abrasive media is required. The cartridge case is coated with a resilient polymer. The plastic can absorb particles due.

Models and installation variants.



The **W flange pump** is the universal pump for horizontal installation.



In-tank W pumps are for in tank installation. Pressure port outside of the tank.

Industrial uses.



Mechanical Engineering.

- Hydraulic pumping up to 120 bar.
- Cool lubricant pumping for gears, motors, turbines and hydraulic systems.
- Benchmarking.
- Lubrication oil applications.
- Cool lubricant pump for machine tools.



Chemical Engineering.

- Processing of abrasive polyols.
- Plastics processing, in particular polyurethane applications.
- Drainage pumping in tanks systems for adhesives, wax, resins and fuel, PUR or coloring agents.
- Apportioning of fluids.
- Drum discharge pump.



Power Generation.

- Raising turbine bearings.
- Increasing pressure and circulation in lubrication systems.

KRAL Magnetic Coupling Pumps.

No more mechanical seal problems.

KRAL pumps are also available with magnetic seals. Magnetic coupled pumps from KRAL are maintenance free, hermetically sealed and can be used at temperatures of up to 300 °C. Additionally, the lifespan of the ball bearings is considerably extended.

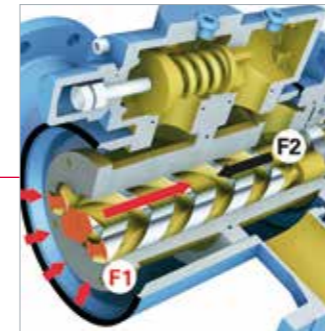
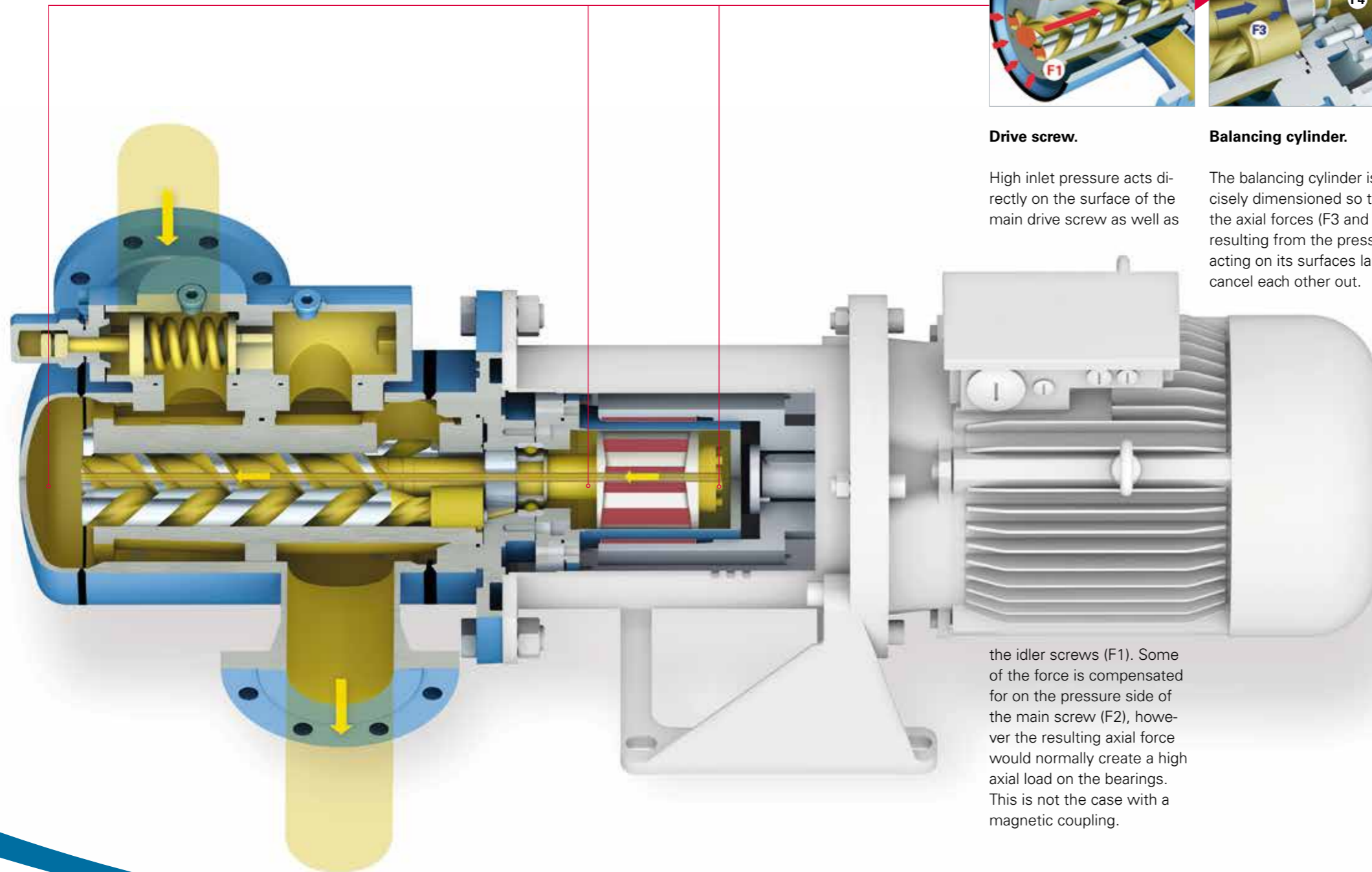

Drive screw.

High inlet pressure acts directly on the surface of the main drive screw as well as

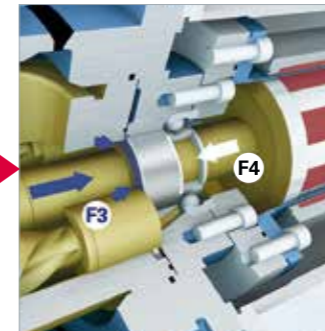

Balancing cylinder.

The balancing cylinder is precisely dimensioned so that the axial forces (F3 and F4) resulting from the pressures acting on its surfaces largely cancel each other out.

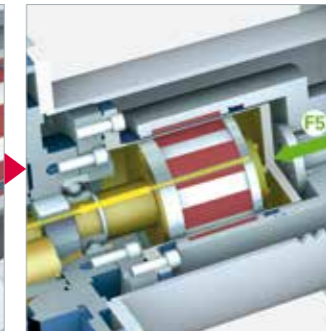

Magnetic coupling.

Thanks to an opening through the centre of the drive screw, the suction side pressure conditions are also present within the containment can of the magnetic coupling. Due to this special design, a force is created (F5) that compensates for the axial thrust on the main spindle. The load on the bearings is minimized leading to longer and more trouble-free operation.



High inlet pressure.

High inlet pressure can cause enormous load on the ball bearings as well as the mechanical seal.

A conventional pump with high inlet pressure requires expensive mechanical seal solutions, structural reinforcement and liquid channels for hydraulic balancing.

The magnetic coupling design eliminates the axial forces, resulting in only minimal load on the ball bearings due to the given conditions. The life expectancy of the ball bearings is thus independent of the inlet pressure, and the magnetic coupling replaces a costly mechanical seal. This means a better pump solution.



Best material quality.

Highest quality materials can withstand high pressures and guarantee minimal eddy current losses at the magnetic coupling.

the idler screws (F1). Some of the force is compensated for on the pressure side of the main screw (F2), however the resulting axial force would normally create a high axial load on the bearings. This is not the case with a magnetic coupling.

KRAL Compact Stations EK/EL.

Oil burner supply station –
oil burner pump with additional functions.

■ **Expansion valve.**

Expansion valve with timer.

■ **KRAL Volumeter®.**

For highly precise flow through metering.

■ **Differential pressure monitoring.**

An optical display or an electrical differential monitor with signal can be used.

■ **Pump variations.**

Single stations can be set up with KRAL KFT series pumps for pressures up to 16 bar or LFM series pumps for up to 40 bar.

■ **KRAL electronics.**

Error free operation, informative monitoring.

■ **Pressure switch.**

A pressure switch serves as an additional pressure monitor.

■ **Leak oil monitoring.**

A leak oil monitoring system is available for installation in an oil pan.

■ **Heating.**

For preheating highly viscous fluids.

■ **Strainer monitoring.**

A suction-side manometer is used to monitor contamination of the strainer.

■ **Constant feed pressure.**

The pressure maintaining valve ensures constant feed pressure, even for erratic fuel demand.

■ **Constant pressure monitoring.**

A manometer is fitted to the middle of the station to allow for monitoring of the feed pressure.

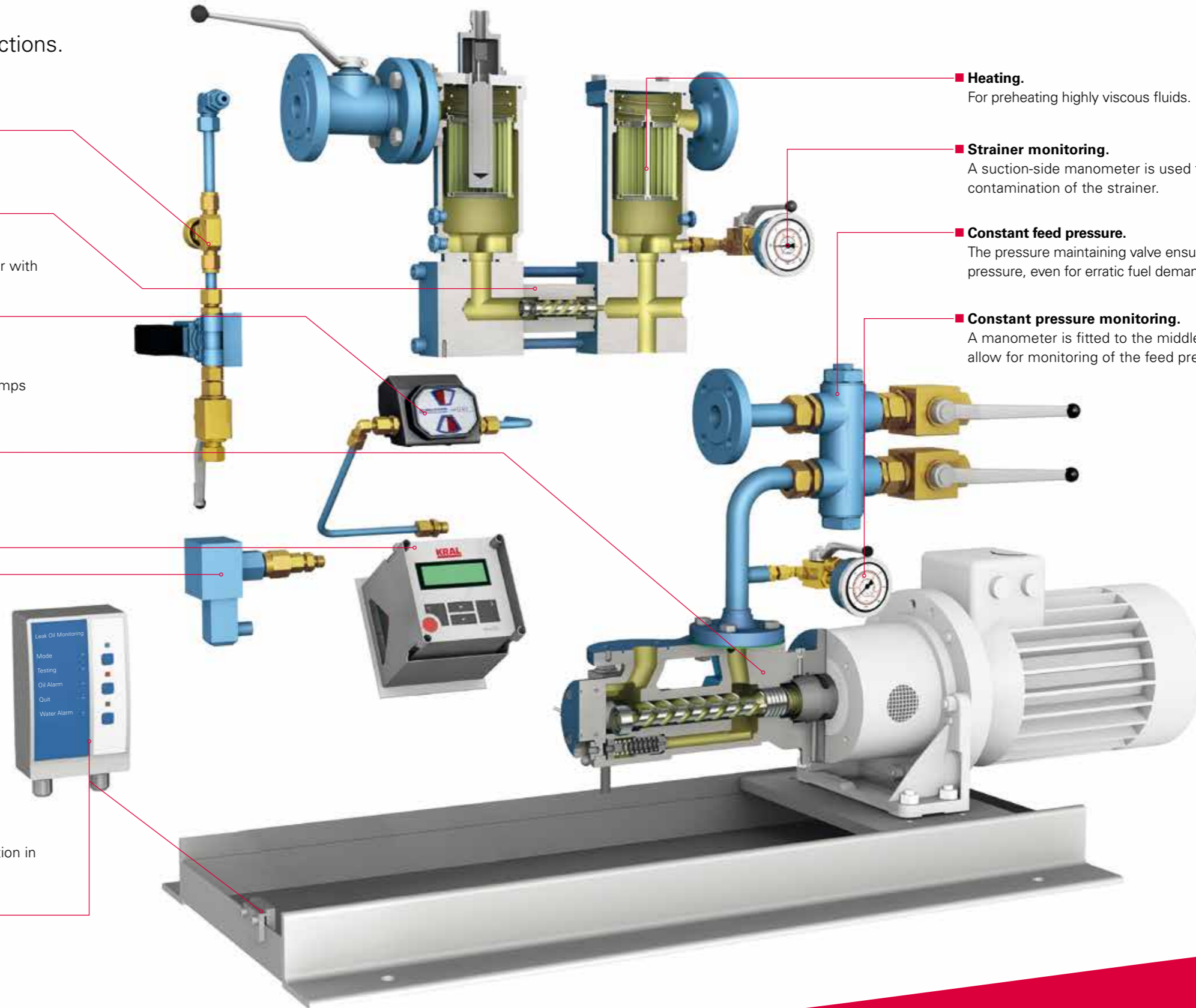

■■■■■ Pumps

KRAL Compact Stations DKC, DLC, DS/L.

Two pumps provide more than double the advantages.

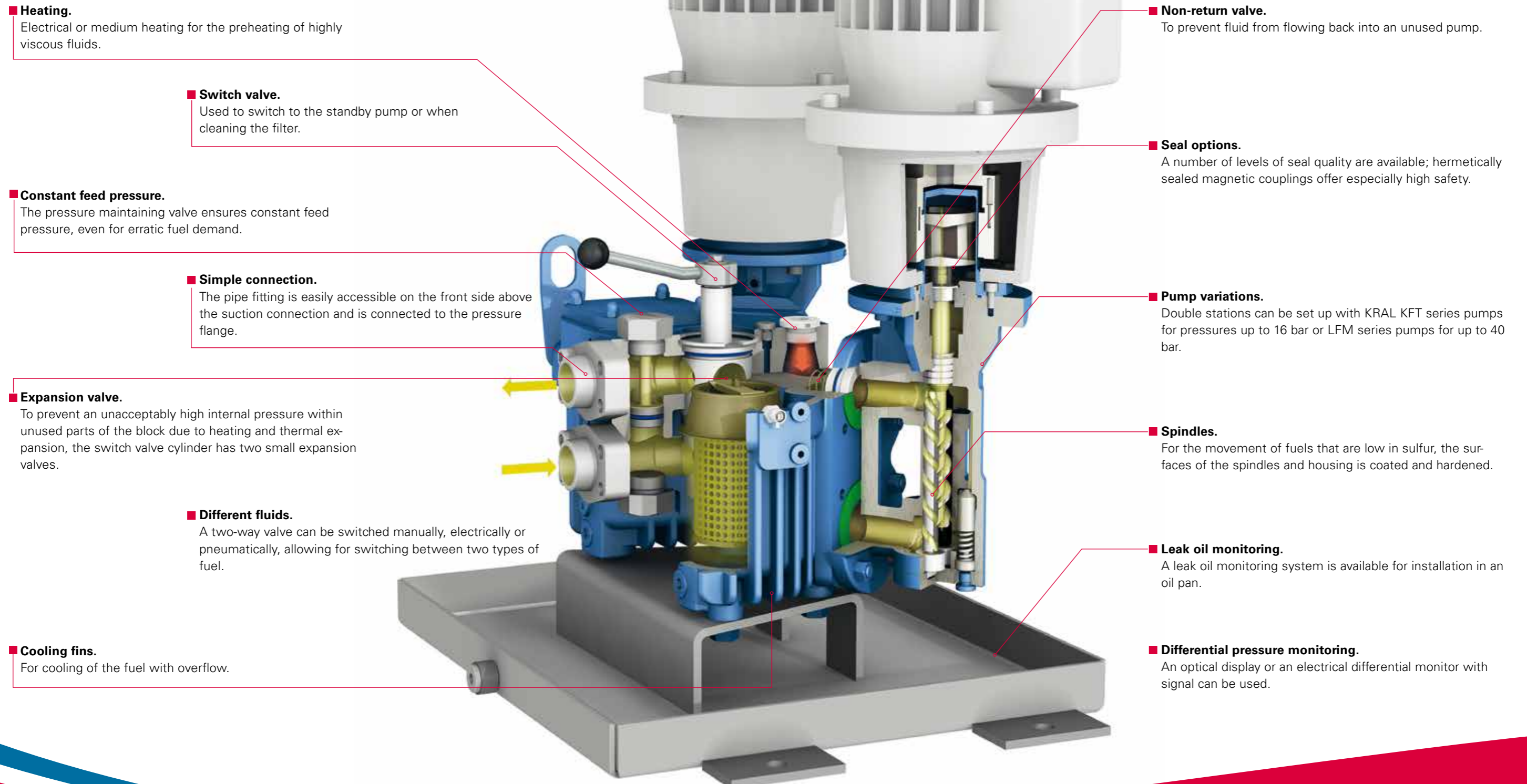

- **Heating.**
Electrical or medium heating for the preheating of highly viscous fluids.
- **Switch valve.**
Used to switch to the standby pump or when cleaning the filter.
- **Constant feed pressure.**
The pressure maintaining valve ensures constant feed pressure, even for erratic fuel demand.
- **Simple connection.**
The pipe fitting is easily accessible on the front side above the suction connection and is connected to the pressure flange.
- **Expansion valve.**
To prevent an unacceptably high internal pressure within unused parts of the block due to heating and thermal expansion, the switch valve cylinder has two small expansion valves.
- **Different fluids.**
A two-way valve can be switched manually, electrically or pneumatically, allowing for switching between two types of fuel.
- **Cooling fins.**
For cooling of the fuel with overflow.
- **Non-return valve.**
To prevent fluid from flowing back into an unused pump.
- **Seal options.**
A number of levels of seal quality are available; hermetically sealed magnetic couplings offer especially high safety.
- **Pump variations.**
Double stations can be set up with KRAL KFT series pumps for pressures up to 16 bar or LFM series pumps for up to 40 bar.
- **Spindles.**
For the movement of fuels that are low in sulfur, the surfaces of the spindles and housing is coated and hardened.
- **Leak oil monitoring.**
A leak oil monitoring system is available for installation in an oil pan.
- **Differential pressure monitoring.**
An optical display or an electrical differential monitor with signal can be used.

■■■■■■ We Pump and Measure Liquids

The 4 KRAL AG Business Units.

Getting an overview.

KRAL AG is organised into four strategic business units. The close cooperation between sales and tech development results in products that offer the highest value for customers.



KRAL ■■ Pumps

KRAL screw spindle pumps have been around ever since 1950. Experience, passed down from generation to generation, is constantly being expanded. This is guaranteed by our highly trained, well qualified personnel.



KRAL ■■ Flow Measurement

KRAL flow meters measure liquids. This broad area of application spans from low viscosity media like petrol, acids and to high viscous liquids like print color and bitumen.



KRAL ■■ Fluid Handling Solutions

It's exactly in more difficult applications like pumping and measuring heavy fuel oils or low sulphur fuels that KRAL AG has a wealth of knowledge. This understanding is incorporated into the development of our own products and their operation in the systems of our customers.



KRAL ■■ Services

You have chosen a great partner with KRAL. After the purchase, a reliable and fast service team is there for you and supports you.

All-Round Service.

The level of service that's right for you.

Everything from a single source for you.

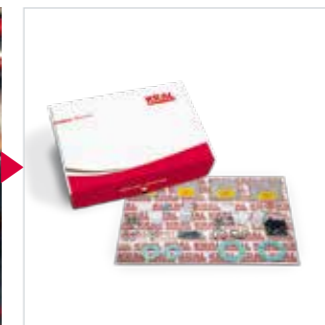

Commissioning.

Our trained service personal get your pumps up and running. Expert setup and a professional commissioning form the foundation of trouble-free operation.

Maintenance and repair.

Increase operating security while preventing failures and keeping the lifecycle costs of pumps and pump systems low. We carry out maintenance and repairs in Lustenau, Austria, or we can come to you.

Spare parts.

Original parts from KRAL guarantee the highest quality standard.

We've got you covered thanks to our spare part concept – you receive all the parts you need for professional maintenance as a set, including lubricants and tools.

Training.

KRAL training provides you with comprehensive proficiency in terms of the setup, commissioning and maintenance of your KRAL pump.

You receive expert instruction from the manufacturer about how to properly assemble and commission your KRAL pump. You'll become familiar with pump usage and limitations, and you'll learn how to recognize and correct malfunctions that might arise.

Working together with you, we can carry out a professional servicing and show you how to reduce the operational costs of your pump.

