

Centrale di evacuazione gas anestetici GSE

Anaesthetic gas evacuation system model GSE

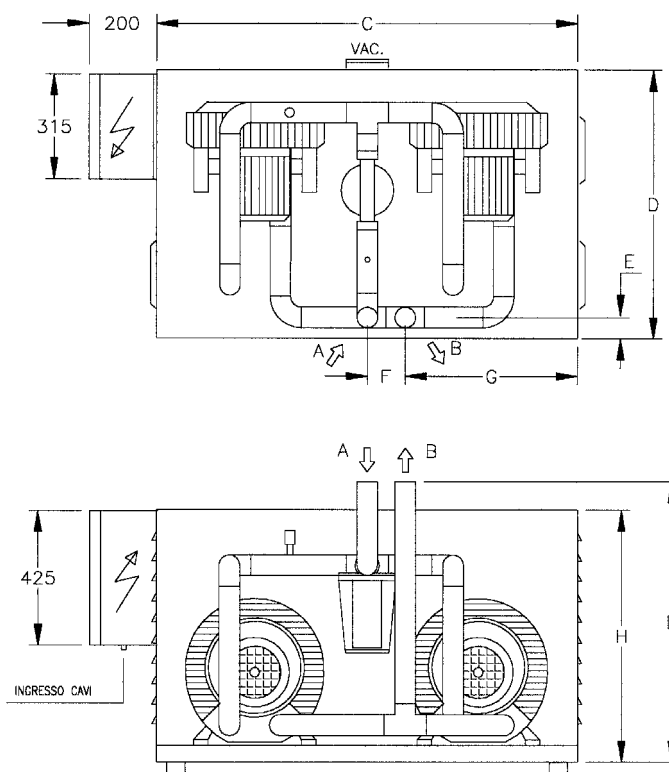

		Modello/Model			
		GSE 30	GSE 70	GSE 100	GSE 130
Dimensioni (mm) Dimensions (mm)	A	1" G	1¼" G	1½" G	1½" G
	B	1" G	1¼" G	1½" G	1½" G
	C	700	800	900	960
	D	500	550	650	700
	E	35	35	50	50
	F	130	140	150	110
	G	240	260	300	400
	H	600	600	600	700
	L	650	650	650	750
Peso/Weight	kg	60	80	100	110

Filtro battericida fissaggio a parete Anti-bacteria filter wall fixing model



1 ATTACCO VALVOLATO PER VUOTOMETRO E ALLARME MANCANZA VUOTO
2 VALVOLE DI ESCLUSIONE
3 PREFILTRO CON CARTUCCIA IN VILEDON
4 FILTRO BATTERICIDA CON RILEVATORE DI INTASAMENTO CARTUCCIA
5 DRENAGGIO FILTRO E AMPOLLA RACCOGLI LIQUIDI

1 VACUUMSWITCH FITTING AND VACUUM FAILURE ALARM
2 INTERCEPTING VALVES
3 VILEDON CARTRIDGE PRE-FILTER
4 ANTI-BACTERIA FILTER WITH CARTRIDGE FULL-UP DEVICE
5 FILTER DRAINAGE AND LIQUIDS COLLECTING AMPOULA

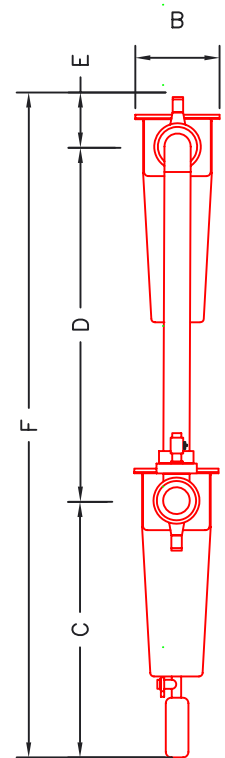
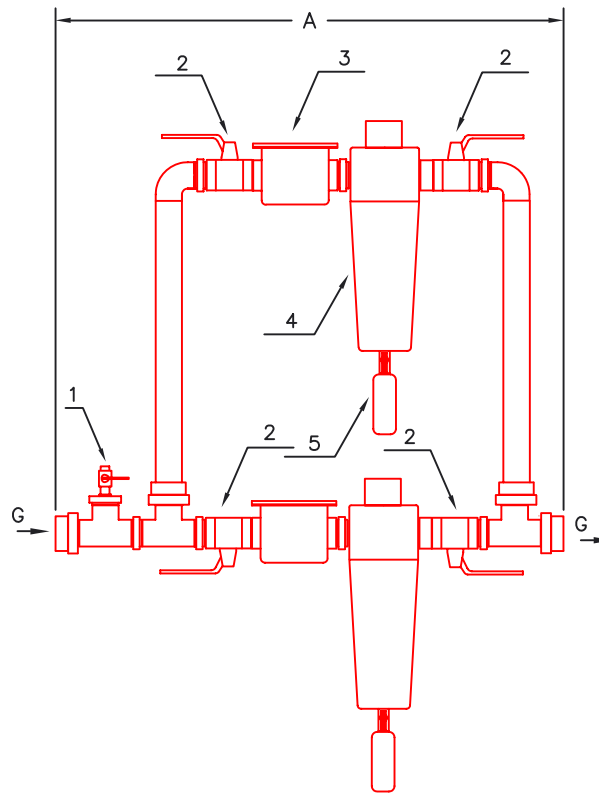

		Gruppo vuoto tipo/Vacuum package model						
		GP 15x3	GP 25x3	GP 45x3	GP 65x3	GP 100x3	GP 210x3	GP 308x3
Dimensioni (mm) Dimensions (mm)	A	620	620	620	620	880	1070	1070
	B	90	90	90	90	130	170	170
	C	390	390	390	390	450	545	545
	D	590	590	590	590	600	750	750
	E	90	90	90	90	120	180	180
	F	1070	1070	1070	1070	1180	1500	1500
	G	½" G	½" G	½" G	½" G	1½" G	1½" G	1½" G
Tipo cartuccia prefiltro Cartridge prefilter model		Carta Paper	Carta Paper	Carta Paper	Carta Paper	Carta Paper	Viledon	Viledon
Filtro battericida Anti-bacteria filter	FFMVE	30	30	150	150	150	350	350

Gruppo filtro battericida

Anti-bacteria filter group

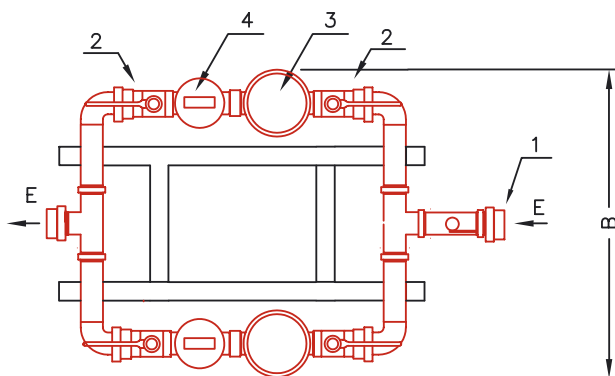
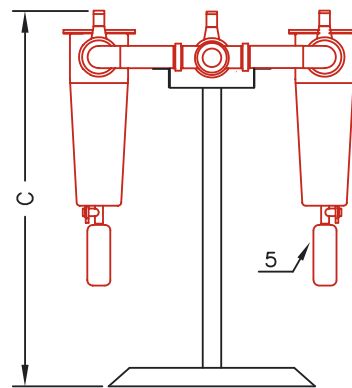
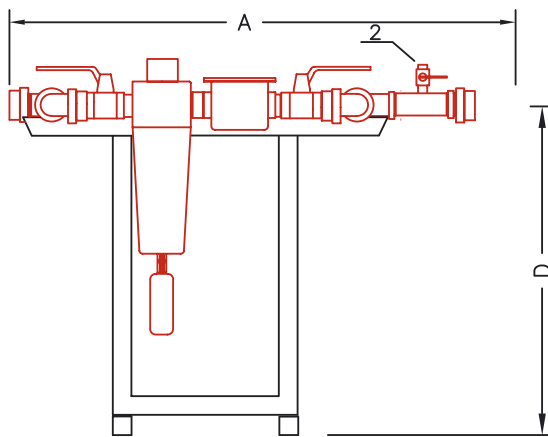

- 1 ATTACCO VALVOLATO PER VUOTOMETRO E ALLARME MANCANZA VUOTO
- 2 VALVOLE DI ESCLUSIONE
- 3 PREFILTRO CON CARTUCCIA IN VILEDON
- 4 FILTRO BATTERICIDA CON RILEVATORE DI INTASAMENTO CARTUCCIA
- 5 DRENAGGIO FILTRO E AMPOLLA RACCOGLI LIQUIDI

- 1 VACUUMSWITCH FITTING AND VACUUM FAILURE ALARM
- 2 INTERCEPTING VALVES
- 3 VILEDON CARTRIDGE PRE-FILTER
- 4 ANTI-BACTERIA FILTER WITH CARTRIDGE FULL-UP DEVICE
- 5 FILTER DRAINAGE AND LIQUIDS COLLECTING AMPOULA

		Gruppo vuoto tipo/ <i>Vacuum package model</i>						
		GP 15x3	GP 25x3	GP 45x3	GP 65x3	GP 100x3	GP 210x3	GP 308x3
Dimensioni (mm) <i>Dimensions (mm)</i>	A	1150	1150	1150	1150	1150	900	900
	B	680	680	680	680	680	500	500
	C	900	900	900	900	900	900	900
	D	760	760	760	760	760	760	760
	E	1" G	1" G	1" G	1" G	1" G	1½" G	1½" G
Filtro battericida <i>Anti-bacteria filter</i>	FFMVE	150	150	150	150	150	350	350

Kit 3^a pompa Third pump kit

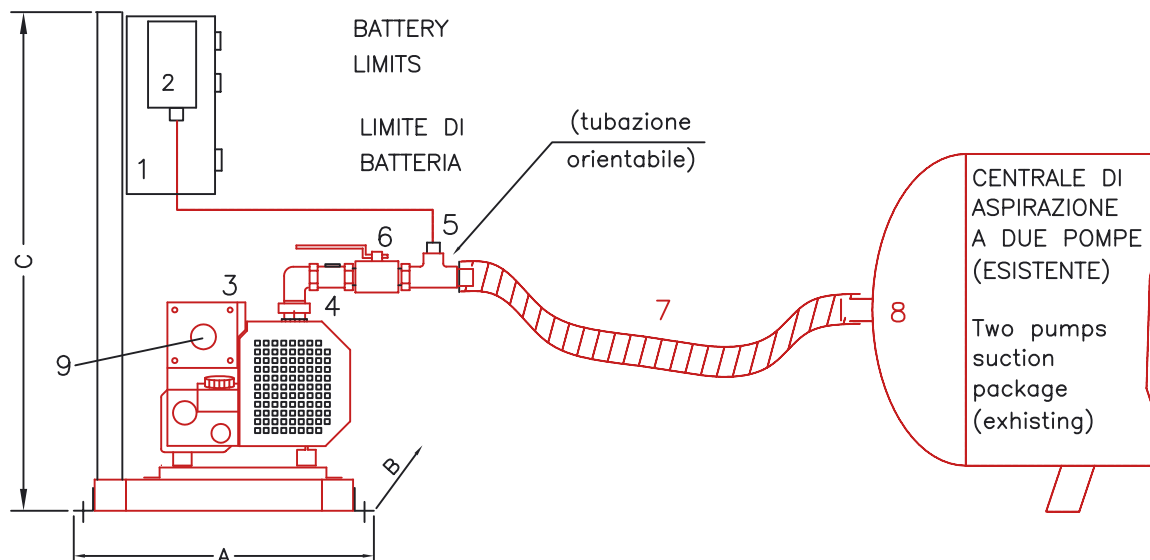

LEGENDA

- 1 PANNELLO ELETTRICO
- 2 VACUOSTATO
- 3 POMPA VUOTO
- 4 VALVOLA DI NON RITORNO
- 5 PRESA VUOTO PER POS. 2)
- 6 VALVOLA INTERCETTAZIONE
- 7 TUBO FLESSIBILE (LUNGHEZZA STANDARD 2 m)
- 8 MANICOTTO DI RISERVA SUL SERBATOIO POLMONE
- 9 SCARICO POMPA

LEGEND

- 1 ELECTRIC BOARD
- 2 VACUUM-SWITCH
- 3 VACUUM PUMP
- 4 NON RETURN VALVE
- 5 VACUUM-SWITCH FITTING
- 6 INTERCEPTING VALVE
- 7 FLEXIBLE HOSE (STANDARD LENGHT 2 m)
- 8 ADDITIONAL HANDLE ON TANK
- 9 PUMP DISCHARGE

		Pompa tipo/Pump model						
		KGP 11	KGP 15/25	KGP 45	KGP 65	KGP 100	KGP 210	KGP 308
Dimensioni (mm) Dimensions (mm)	A	450	450	450	450	570	750	750
	B	670	670	670	670	830	1100	1100
	C	700	700	700	700	700	800	800
Potenza motore Motor power	kW	0,55	0,55/0,75	1,1	1,5	2,2	4	7,5
Peso gruppo Weight	Kg	50	50	70	75	170	200	240